

THUDBUSTER®

THUDBUSTER ST INSTRUCTIONS INITIAL INSTALLATION

- Note your current saddle height and fore/aft position to duplicate it with the Thudbuster.
- Remove your current saddle and seatpost.
- Confirm your new Thudbuster seatpost (or shim) diameter is the same as your old seatpost. (Thudbusters are available in six direct fit sizes between 25.4 and 31.6 mm.)
- Grease the shim (if applicable) and seat pillar before installing. **DO NOT** lubricate seat tubes of Carbon frames (unless specified by the manufacturer).
- Insert the shim (if applicable) into the bicycle frame with the split aligned with the split in the seat-tube.
- Install the Thudbuster into the bicycle frame to approximately the correct height with the extension marks on seat pillar facing the front of the bicycle.
- Loosen the two saddle clamp bolts (front and rear) until the threads are barely engaging the barrel nuts (1 or 2 threads). Be sure grease is applied to the interface between the lower clamp and cradle.
- Place one rail of saddle in position between the upper and lower clamps. Then rotate saddle so the other rail slips over the far edge of the upper clamp and into position in the rail grooves of the lower clamp.
- Begin to tighten the front and rear clamp bolts. The saddle tilt adjustment is controlled by these two bolts. Check that the saddle tilt and fore/aft position of the saddle are correct before final tightening. The front bolt can be adjusted by hand or hex wrench, but the rear bolt must be tightened to 60 in*lb (6.8 N*m) with a 4 mm hex wrench. Be sure all the components of the clamp are installed as shown in section view. (Figure 1)
- Adjust the saddle height if necessary.

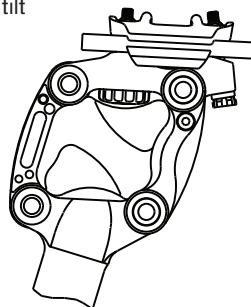
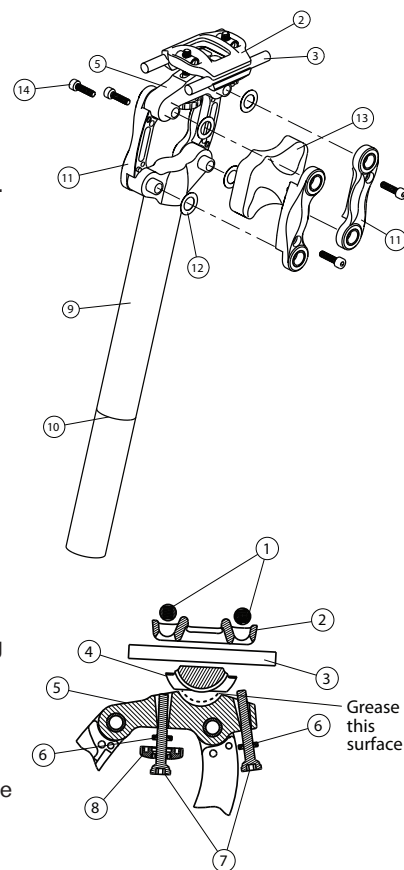

- ① Barrel nut (2)
- ② Upper clamp
- ③ Saddle rails
- ④ Lower clamp
- ⑤ Cradle
- ⑥ Spherical washer (2)
- ⑦ Clamp bolt (2)
- ⑧ Adjustment knob
- ⑨ Seat pillar
- ⑩ Minimum insertion line (100mm)
- ⑪ Arm - ST (4)
- ⑫ Pivot washer (8)
- ⑬ Elastomer - ST
- ⑭ Arm bolt, 16mm (4)

NOTICE! The Thudbuster must be set-up with appropriate elastomer before riding (See below). Maximum allowable rider weight is 250 lb (115kg).

SELECTING ELASTOMERS

The Thudbuster ST can be tuned for different weight riders and riding styles by selecting the correct elastomer. Start with the softest elastomer recommended for a given rider weight. The Thudbuster ST is shipped with a soft, medium, and hard elastomer. You may desire to increase the stiffness by using harder a elastomer. Never use a softer elastomer than recommended for your weight.

Rider Weight		Minimum Elastomer Recommendation
(Pounds)	(kg)	
Under 100	Under 45	extra soft - #1*
100-140	45-64	soft - #3
140-190	64-86	medium - #5
190-250	86-114	hard - #7
Over 250	Over 114	Exceeds post limit

*#1 (extra soft) and #9 (extra hard) elastomers are available separately from www.canecreek.com

CHANGING ELASTOMER

1. Using a 3 mm hex wrench, loosen the two screws on the front arm assembly—one on each side.
2. Slide one half of the front arm off the pivots. Wiggling the saddle fore and aft while pulling on the arm half will make it easier to remove.
3. Push the elastomer out of the linkage pockets.
4. Insert the new elastomer in the linkage pockets. Be sure to orient the elastomer properly. The concave cuts should be on the top and bottom enabling clearance for the front clamp bolt on the underside of the cradle.
5. Check that the brass washers are still in place on the pivot pins.
6. Reassemble the front arm half on the pivot pins being careful not to pinch the elastomer.
7. Reassemble the two screws and tighten to 30 in*lb (3.4N*m).

The Thudbuster ST elastomer is made from natural rubber for its favorable damping characteristics but unlike the urethane LT elastomers, natural rubber can not be effectively colored and as a result all ST elastomers are black. To identify the stiffness of each ST elastomer, find the small dial that is molded into one side. The arrow indicates the elastomer's relative stiffness. 1 is extra-soft while 9 is extra firm, 5 is medium. This elastomer is a #3 or "soft" model.

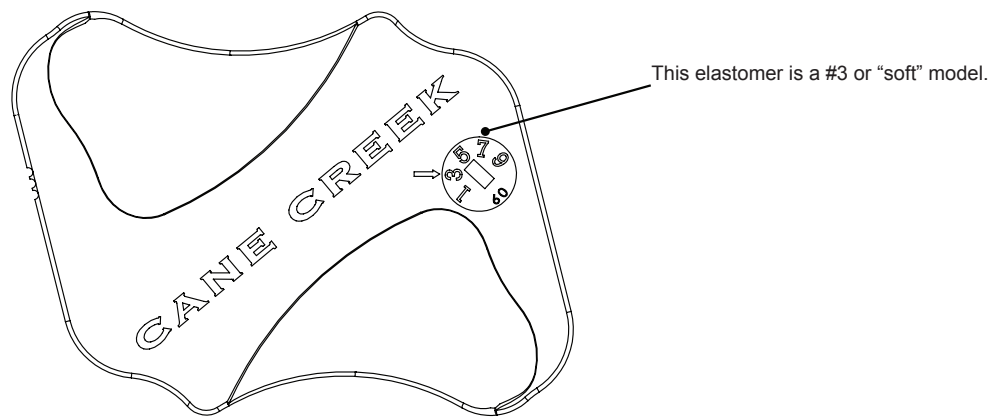

MAINTENANCE

1. The pivot washers should occasionally be lubricated with a light oil.
2. The skewer and elastomers must be lubricated periodically with grease. Apply grease to the shaft of the skewer and to the ends of the elastomers. The elastomers must be removed and reassembled as explained in the changing elastomers section of the instructions.

NOTICE! If you ride in muddy conditions, using either a fender or the Cane Creek Thudglove neoprene boot will protect the pivots and extend the life of your seatpost.

NOTICE! Thudbuster seatposts are designed to absorb small bumps only. You should still stand up when encountering large obstacles on the road or trail.

WARRANTY

Thudbuster seatposts are warranted against defects in materials or workmanship for one year from the date of purchase. This warranty applies to the original owner only. At their discretion, Cane Creek Cycling Components will repair or replace any defective seatpost with the same or comparable model. This warranty is void if the seatpost is damaged as a result of abuse, alterations, modifications, improper adjustment, lack of maintenance, crashes, or other conditions judged by Cane Creek Components to be abnormal, excessive, or improper. It is mandatory that a Return Authorization Number (RA#) is received (by calling Cane Creek) before any return is made. Additionally, a dated Proof of Purchase must accompany the seatpost when returned.