

# CONVERSION BOTTOM BRACKETS

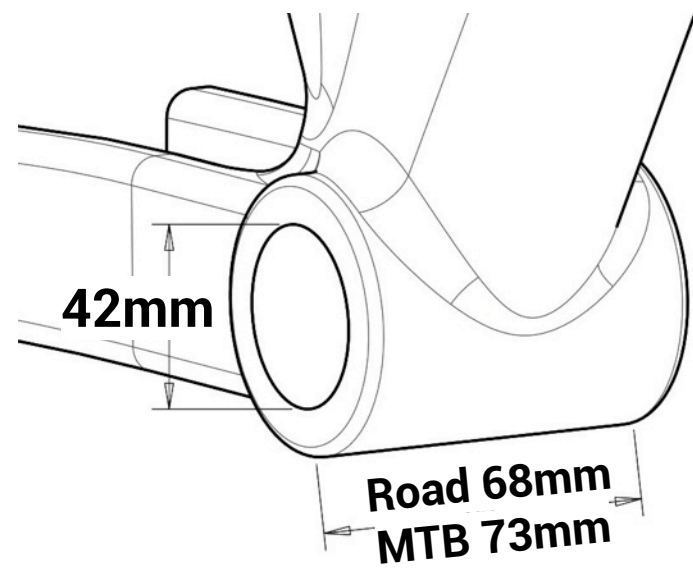

**BB30**

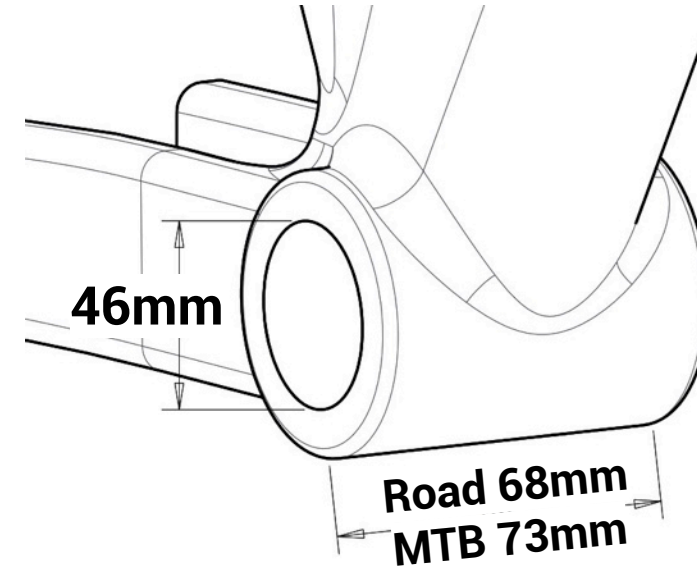

**PF30**

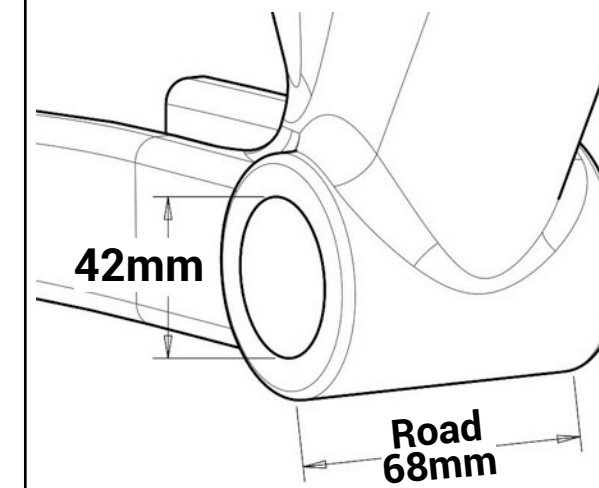

**Specialized**  
OSBB Road AL INNER SHELL

OSBB WITH AL INNER SHELL WITH  
REMOVABLE BB30 C-CLIPS  
(See PAGE 3 of this guide)

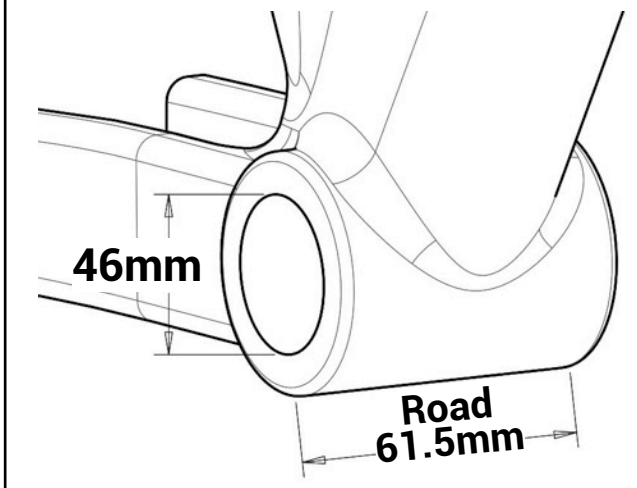

**Specialized**  
OSBB Road Carbon Inner SHELL

OSBB WITH CARBON INNER  
FRAME SHELL INTERFACE  
(See PAGE 3 of this guide)

FRAME TYPE →	ROAD 68MM	MTB 73MM	ROAD 68MM	MTB 73MM	Specialized ROAD	
<b>SHIMANO</b> HOLLOWTECH II	 #68-3001 Steel #68-5001 Ceramic Install BB <b>without</b> included sleeve	 #73-3001 Steel #73-5001 Ceramic Install BB <b>without</b> included sleeve	 #68-3001 Steel #68-5001 Ceramic Install BB <b>with</b> included sleeve	 #73-3001 Steel #73-5001 Ceramic Install BB <b>with</b> included sleeve	 #68-3001 Steel #68-5001 Ceramic <b>AL SHELL</b> Install BB <b>without</b> included sleeve	 #68-3002 Steel #68-5002 Ceramic <b>CARB INNER SHELL</b> Install BB <b>with</b> included 2 sleeves
<b>SRAM</b> GXP/ISI2	 #68-3201 Install BB <b>without</b> included sleeve	 #73-3201 Install BB <b>without</b> included sleeve	 #68-3201 Install BB <b>with</b> included sleeve	 #73-3201 Install BB <b>with</b> included sleeve	 #68-3201 <b>AL SHELL</b> Install BB <b>without</b> included sleeve	 #68-3202 <b>CARB INNER SHELL</b> Install BB <b>with</b> included 2 sleeves
<b>CAMPY</b> ULTRA TORQUE	 #68-3101 Install BB <b>without</b> included sleeve		 #68-3101 Install BB <b>with</b> included sleeve		 #68-3101 Install BB <b>without</b> included sleeve	 #68-3102 <b>CARB INNER SHELL</b> Install BB <b>with</b> included 2 sleeves

# VIP NOTES

- **BB30 frames must have removable C-clips** for Conversion BB to be able to press in.
- **Frame shell cannot have any inner shell obstructions** that prevent BB from installing.
- **NOT** made for BBRight, BB386EVO, BB86, BB92 or Cannondale's new "BB30A"
- **If you are unsure of your bike's BB shell, please contact your frame manufacturer.**

## IMPORTANT - Always look in at your frame shell to be sure first!

These are just some 'custom' frames notes that we have learned/found out about that can cause some installation challenges. We are always editing these notes to keep customers informed as best we can, but please know that this is always changing due to frame manufactures always making production run changes. It is nearly impossible to keep up. If you find a frame not on our list that has a challenge, please let us know with photo of the frame shell.

## E-Wiring Reference

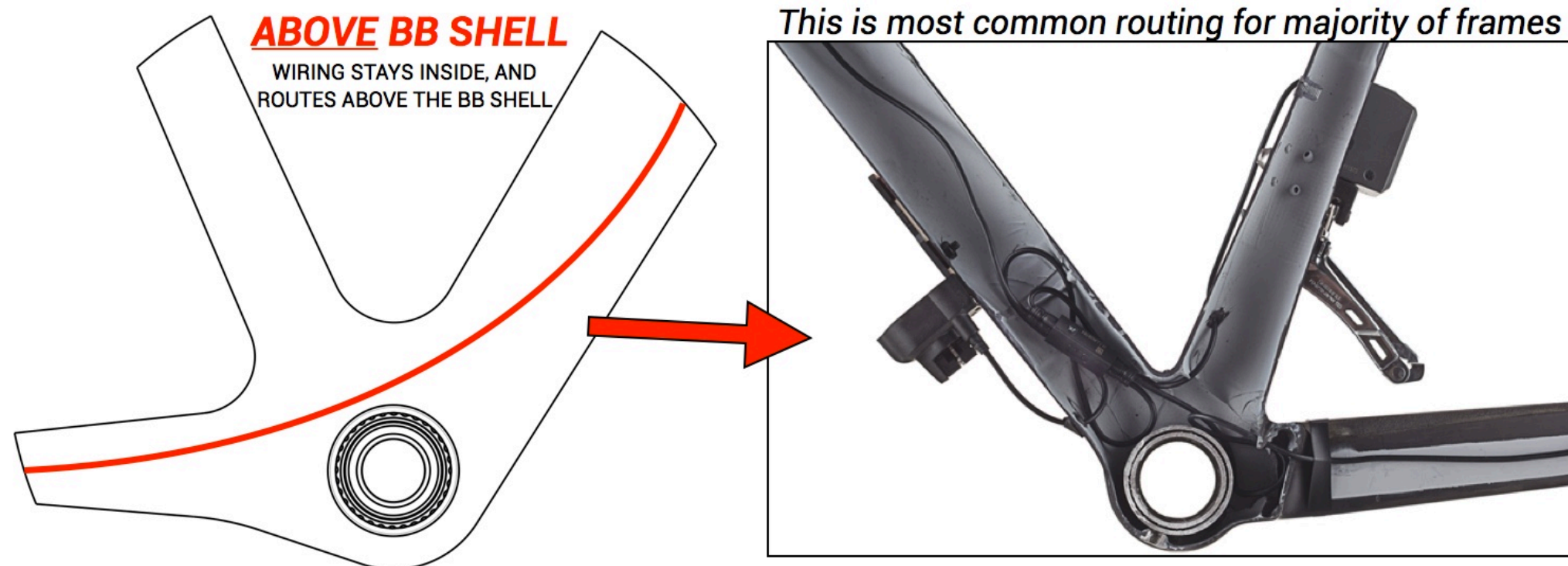

Other options....

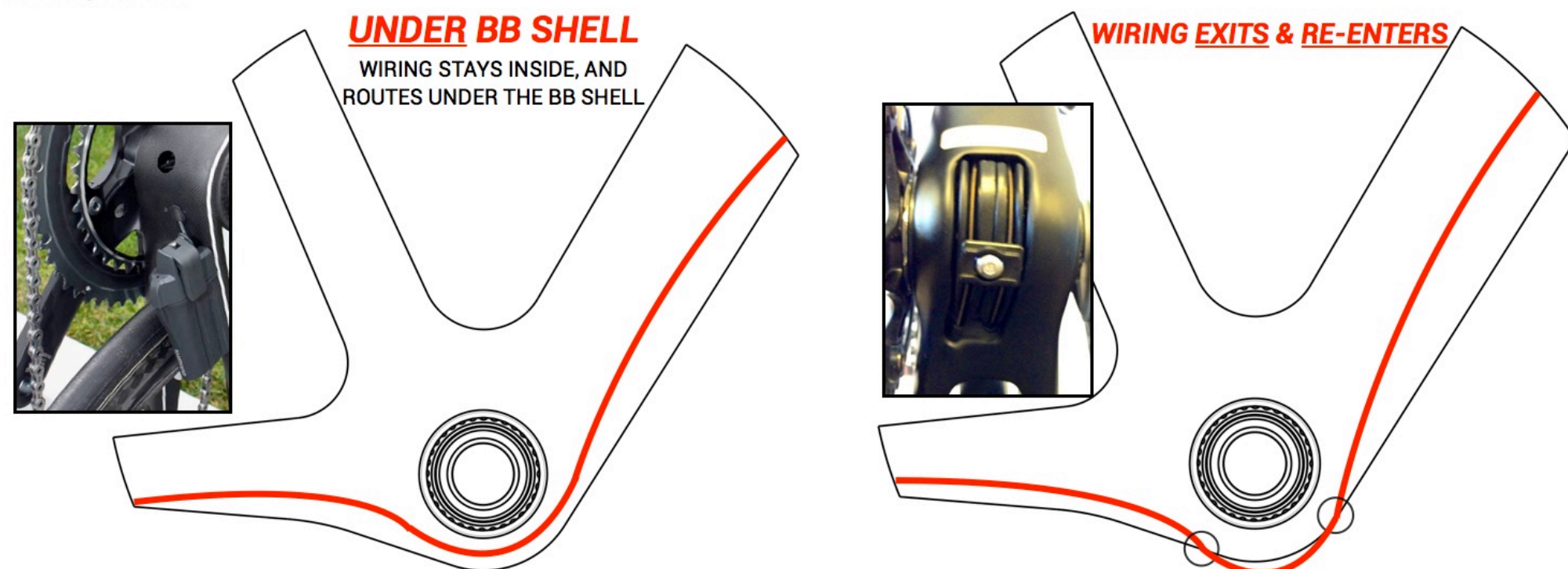

**SMOOTH BORES** - The bores generally must be same diameter all the way through. There simply cannot be a 'rise' in the bore that obstructs the Conversion BB from pressing in. **Always inspect your frame** before installing Conversion BB.

REFERENCE PHOTO  
BB30 = 42MM DIAMETER



REFERENCE PHOTO  
PF30/OSBB CARB= 46MM DIAMETER

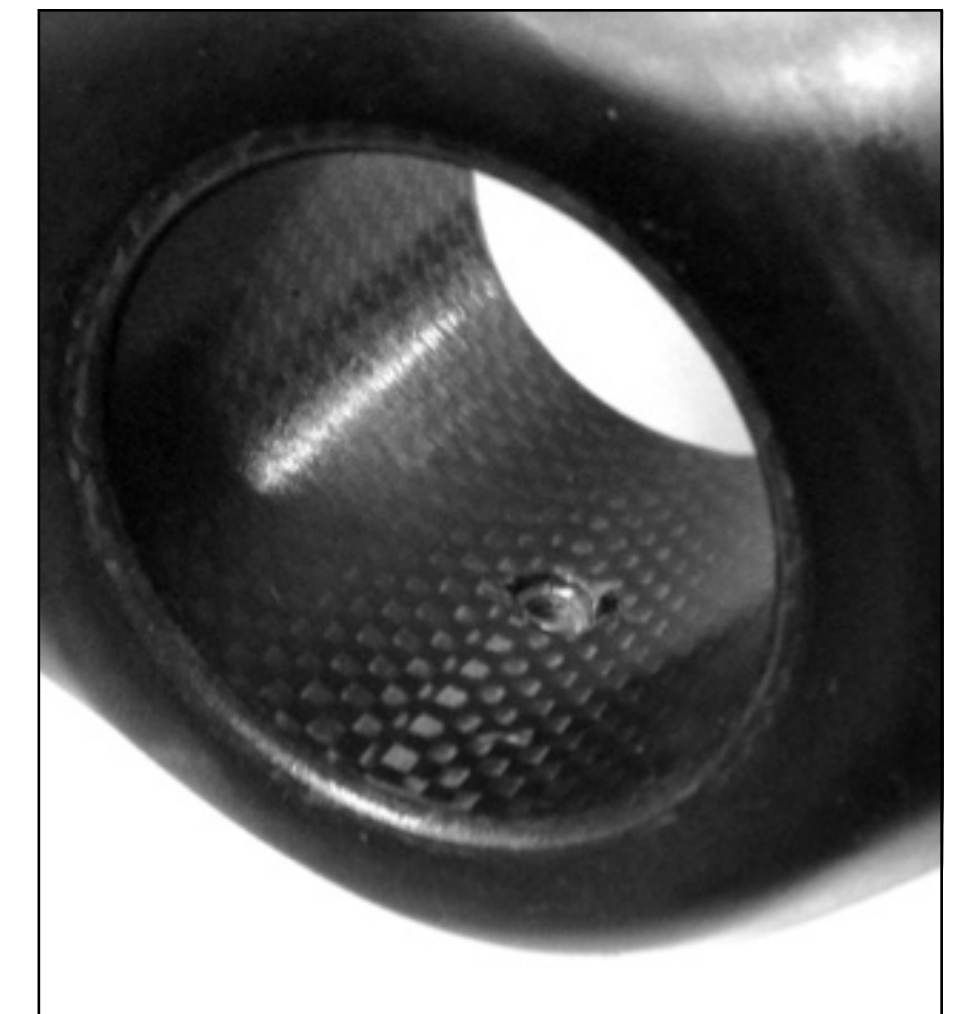

**MECHANICAL CABLE GUIDE** - Every once in a while you might bump into a frame that has a longer cable guide plug/screw that protrudes into the shell. This might prevent the Praxis BB from installing. Most bike shops stock a bunch of different kinds to choose from and most times these can simply be swapped out for a different guide that does not protrude into the frame. If unsure, please see your local bike shop mechanic or check with your frame manufacture. **Do NOT modify your frame ever.**



# SPECIALIZED ROAD "OSBB"

**IMPORTANT - Always visually inspect your specific frame shell to be sure first!**

## **OSBB ROAD** **ALUMINUM INNER SHELL (BB30)**

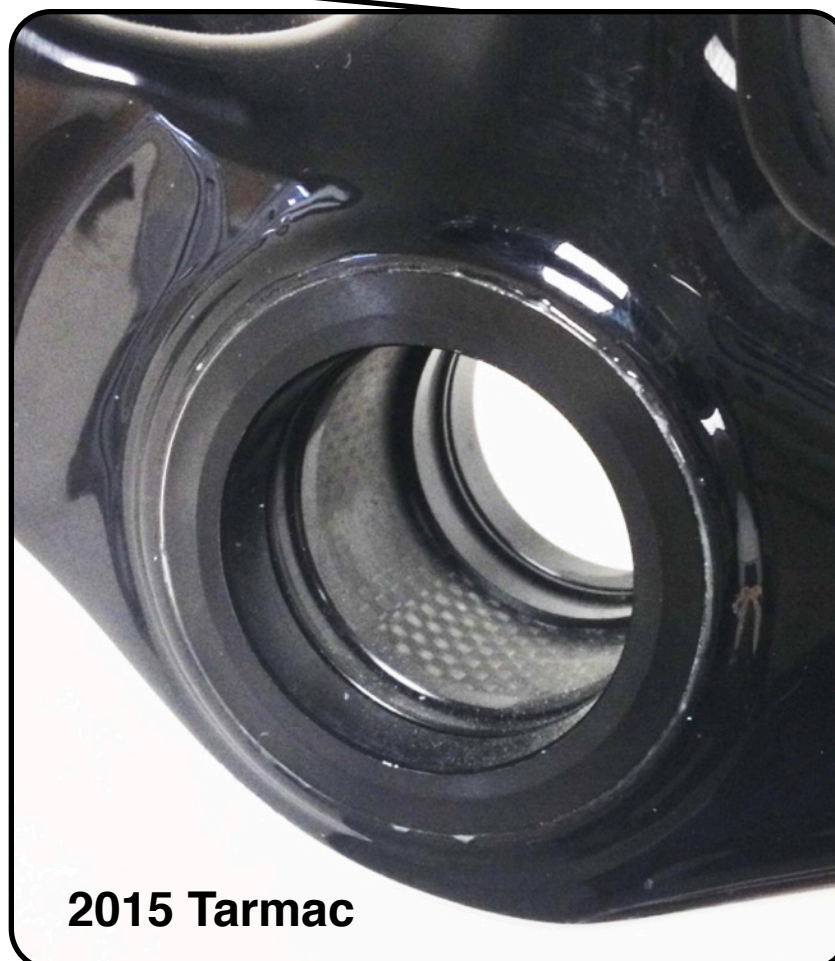

**These are the 3 versions of OSBB Road that utilized an Aluminum Inner Shell over the years.**  
This is essentially a 68mm BB30 frame that is 68mm Wide X 42mm Diameter.

**For these frames simply install any of our 68mm Conversion BB's without the included sleeve.**

## **OSBB ROAD** **CARBON INNER SHELL**



**This is OSBB Road with Carbon Inner Shell.**

The frame shell measures 61.5mm Wide X 46mm Diameter.

Sometimes you see it with the Specialized BB cups/bearings installed in it, other times you see it without a BB installed.  
*Both are shown in these pics above.*

So before installing the Praxis ConvBB, you must remove the Specialized cups and bearings.

For this frame type, order the Praxis Conversion BB **which ships with the custom Praxis OSBB (pair) Delrin sleeves.**

- # 68-3002 - Shimano
- # 68-3202 - SRAM GXP/ISIS2
- # 68-3102 - CAMPY ULT TORQUE



## SPECIALIZED

**ROAD** - Please read the 3rd page here for Specialized OSBB road frames.

**MTN** - 2012-Present are mostly all PF30 frames. 2011 MTB frames were proprietary BB for SBC that is NOT BB30 or PF30 and our ConvBB cannot be used.

## CANNONDALE

**SuperSix EVO** - It is our understanding that this frame comes in 2 versions. A version for mechanical cable routing, and one specifically for Di2 internal wiring. The Conversion BB mounts great in both. *\*However\** if you have the Mechanical version and you're trying to route Di2 inside, the inside of that frame is different and is closed off to the chainstay. Please call Cannondale.

**Synapse '14 w/BB30A** - This is a fully custom 73mm ROAD Asymmetrical BB shell. This FRAME is NOT compatible with the Conversion BB. This frame can only run a Cannondale crank.

**Flash MTB**- Some of these frames use a custom AL shell with a machined lip instead of the spec BB30 C-clips. This custom non-removable lip prevents installation of the Conversion BB. But have a look inside your frame.

## BMC

Many BMC frames over the years were spec BB30 and are perfect with our Conversion BB. However some have switched to other frame BB standards. So you really have to look at your specific model.

**Newer IMPEC** - Some of these frames use a custom AL shell with a fixed machined lip instead of the spec BB30 removable C-clips. **This custom non-removable lip prevents installation of the Conversion BB.** But have a look inside your frame.



## JAMIS

Many *Pre-2014* Jamis frames are spec BB30 or PF30 and are perfect with our Conversion BB. We have now seen 2014 Jamis bikes have switched to BB386EVO and are no longer compatible with our Conversion BB.

**2009 Zenith SL** - This *specific model/year frame* had a 'custom BB30' frame shell and our Conversion BB cannot be installed in it.

## LOOK

**986 MTB, 576 TT** - Many of these are spec BB30, but some recent '13 production use a custom AL shell with a machined lip instead of the spec BB30 C-clips. This custom non-removable lip prevents installation of the Conversion BB. So look inside your frame to see which version you have. If you see a spec BB30 with the removable C-clips...you're good.

## GURU - CERTAIN MODELS

Guru offers PF30 on virtually all their frames and Conversion BB works great with mechanical shifting.

*Internal Wiring* - On the Carbon frames, internal wiring will pass above and over the BB shell. But on their Titanium Frames the Conversion BB will prevent internal wiring from passing through to the chainstay. It's just too tight of a turn and no room for wiring with Conv BB installed.

## FELT

The F1, F2, AND Z1 - These frames use Felt's custom Carbon BB30 with a non-removable carbon sleeve/lip. (see photo) **This custom frame shell prevents installation of the Praxis Conversion BB.**

The F3...F4 and others models are regular spec BB30 and are perfect for our Conversion BB. Always look at your specific frame to be sure.

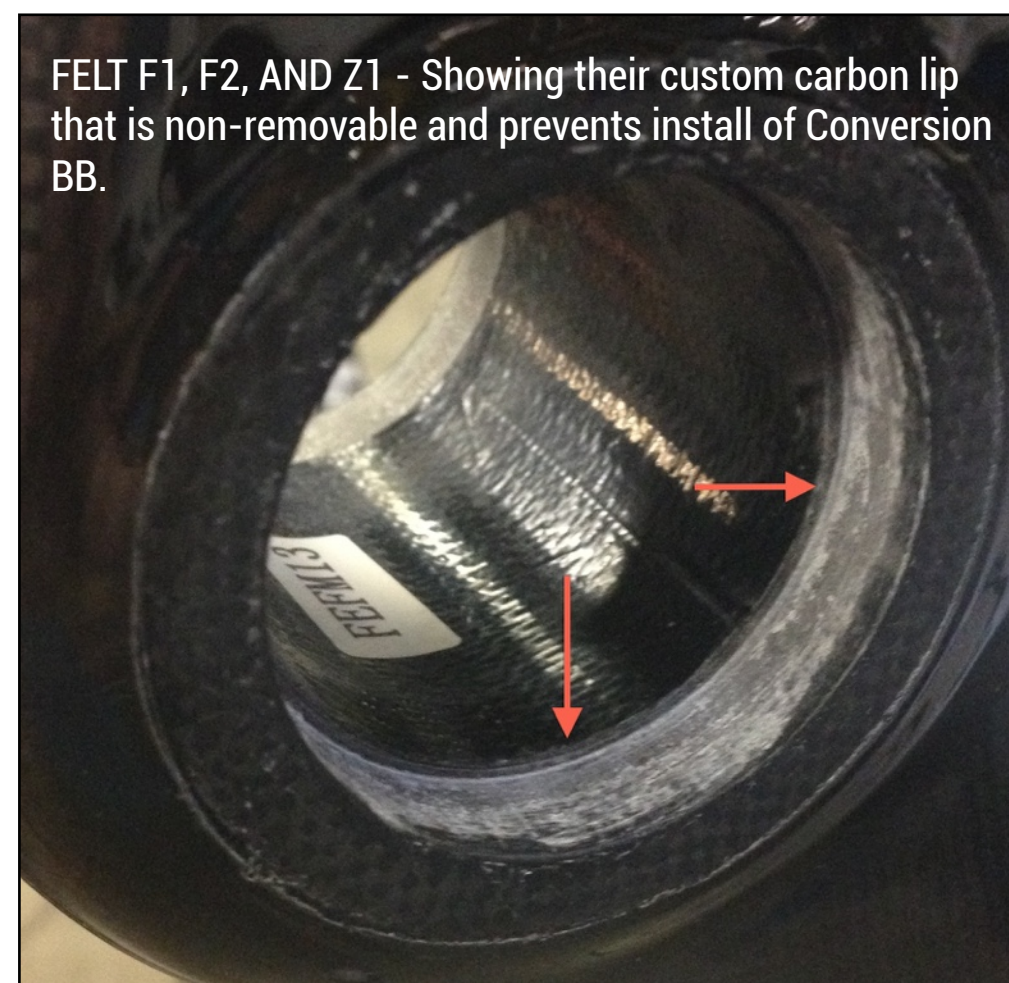

## MOOTS Ti Road Frames

Moots offers PF30 on many of their frames and Conversion BB works great with mechanical shifting.

*Internal Wiring* - On their Titanium Frames the Conversion BB will prevent internal wiring from passing through to the chainstay. It's just too tight of a turn and no room for wiring with Conv BB installed.

## NINER - MTB

Many Niners are perfect for our Conversion BB. But *some* of their frames have internal shifting cables routing directly through the BB shell and this creates a challenge. However some frames allow you to omit the internal routing and go external routing so that the BB install is perfect.

**AIR9 (PF30 ALLOY) - GOOD**

**AIR9 RDO** - Recent '13 versions are GOOD as there is a new channel for the cables to nestle below the BB, **but older versions** prevent the Conversion BB installation.

**JET9 RDO** - Cable guide created internal interference. **Check with Niner**

Always look inside your specific Niner frame to be sure.

## PINARELLO

Rokh Frame - We have seen these frames use a custom AL PF shell that has a change of diameter inside the frame shell. **There is slight lip that prevents installation of the Conversion BB.** See photo here.

